

**Consumables**

	Centricut P/N	Raysoar P/N	OEM Ref. No.	Description	Pkg qty
1	MZ368-4430CP			MZ-Nozzle, 1.0 mm CP	1
	MZ368-4470CP		46143304470	MZ-Nozzle, 1.2 mm CP	1
	MZ368-4450CP		46143304450	MZ-Nozzle, 1.5 mm CP	1
	MZ368-4460CP		46143304460	MZ-Nozzle, 2.0 mm CP	1
	MZ368-4480CP		46143304480	MZ-Nozzle, 2.5 mm CP	1
	MZ368-4490CP		46143304490	MZ-Nozzle, 3.0 mm CP	1
	MZ368-4500CP		46143304500	MZ-Nozzle, 3.5 mm CP	1
	MZ368-4510CP		46143304510	MZ-Nozzle, 4.0 mm CP	1
2	MZ373-0001			MZ-Nozzle double, 1.2 mm CP	1
	MZ368-0005CP		46143306450	MZ-Nozzle double, 1.5 mm CP	1
	MZ373-0003		46143306460	MZ-Nozzle double, 2.0 mm CP	1
	MZ373-0004		46143306480	MZ-Nozzle double, 2.5 mm CP	1
	MZ373-0005		46143306490	MZ-Nozzle double, 3.0 mm CP	1
	MZ373-0006		46143306500	MZ-Nozzle double, 3.5 mm CP	1
	MZ373-0007		46143306510	MZ-Nozzle double, 4.0 mm CP	1
3	MZ427-0002			MZ-Nozzle, 1.2 mm	1
4	MZ368-0740		36143310740	MZ-Nozzle holder	1
5	MZ368-0001		36143304420	MZ-Nozzle holder Hyper Gear	1

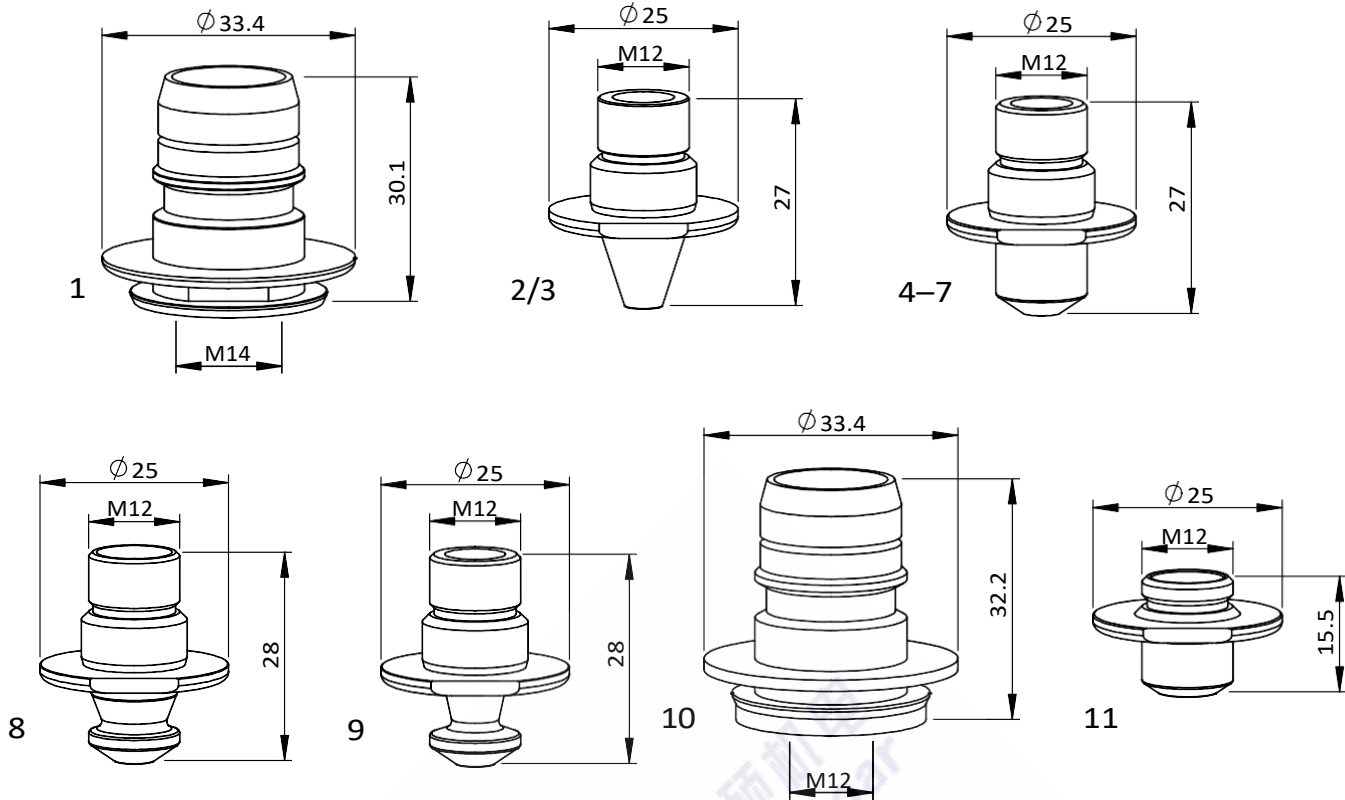

## Consumables

	Centricut P/N	Raysoar P/N	OEM Ref. No.	Description	Pkg qty
1	MZ368-0522		36143310522E, 36143310522, 36143310523	MZ-Nozzle holder	1
2	MZ373-0310CPX		46143310332	MZ-Nozzle slim, 1.0 mm CP (10 pk)*	10
	MZ373-0341CPX		46143310341, 46143310342, 46143310343	MZ-Nozzle slim, 1.2 mm CP (10 pk)*	10
	MZ373-0351CPX		46143310351, 46143310352, 46143310353	MZ-Nozzle slim, 1.5 mm CP (10 pk)*	10
	MZ373-0361CPX		46143310361, 46143310362, 46143310363	MZ-Nozzle slim, 2.0 mm CP (10 pk)*	10
	MZ373-0371CPX		46143310371, 46143310372, 46143310373	MZ-Nozzle slim, 2.5 mm CP (10 pk)*	10
	MZ373-0381CPX		46143310381, 46143310382, 46143310383	MZ-Nozzle slim, 3.0 mm CP (10 pk)*	10
	MZ373-0391CPX		46143310391, 46143310392, 46143310393	MZ-Nozzle slim, 3.5 mm CP (10 pk)*	10
	MZ373-0401CPX		46143310401, 46143310402, 46143310403	MZ-Nozzle slim, 4.0 mm CP (10 pk)*	10
3	MZ373-0311CPX		36143311500	MZ-Nozzle double slim, 1.0 mm CP (10 pk)*	10
	MZ373-0312CPX		36143311510, 36143311512	MZ-Nozzle double slim, 1.2 mm CP (10 pk)*	10
	MZ373-0315CPX		36143311520, 36143311522	MZ-Nozzle double slim, 1.5 mm CP (10 pk)*	10
	MZ373-0320CPX		36143311530, 36143311532	MZ-Nozzle double slim, 2.0 mm CP (10 pk)*	10
	MZ373-0325CPX		36143311535, 36143312380	MZ-Nozzle double slim, 2.5 mm CP (10 pk)*	10
	MZ373-0330CPX		36143312390	MZ-Nozzle double slim, 3.0 mm CP (10 pk)*	10
	MZ373-0335CPX			MZ-Nozzle double slim, 3.5 mm CP (10 pk)*	10
	MZ373-0340CPX			MZ-Nozzle double slim, 4.0 mm CP (10 pk)*	10
MZ373-0350CPX			MZ-Nozzle double slim, 5.0 mm CP (10 pk)*	10	

**Consumables**

	Centricut P/N	Raysoar P/N	OEM Ref. No.	Description	Pkg qty
4	MZ373-1581CPX		Q6143312210	MZ-Nozzle pencil, 1.0 mm CP (10 pk)*	10
	MZ373-1582CPX		36143312220	MZ-Nozzle pencil, 1.2 mm CP (10 pk)*	10
	MZ373-1583CPX		36143312230	MZ-Nozzle pencil, 1.5 mm CP (10 pk)*	10
	MZ373-1584CPX		Q6143300060	MZ-Nozzle pencil, 1.8 mm CP (10 pk)*	10
	MZ373-1585CPX		36143312240	MZ-Nozzle pencil, 2.0 mm CP (10 pk)*	10
	MZ373-1587CPX		36143312250	MZ-Nozzle pencil, 2.5 mm CP (10 pk)*	10
	MZ373-1588CPX		36143312260	MZ-Nozzle pencil, 3.0 mm CP (10 pk)*	10
	MZ373-1589CPX		36143312270	MZ-Nozzle pencil, 3.5 mm CP (10 pk)*	10
	MZ373-1590CPX		36143312280	MZ-Nozzle pencil, 4.0 mm CP (10 pk)*	10
	MZ373-1591CPX		06143355590	MZ-Nozzle pencil, 4.5 mm CP (10 pk)*	10
	MZ373-1592CPX		06283301030	MZ-Nozzle pencil, 5.0 mm CP (10 pk)*	10
MZ373-1593CPX		06283301830	MZ-Nozzle pencil, 5.5 mm CP (10 pk)*	10	
5	MZ373-1601CPX			MZ-Nozzle double pencil, 1.0 mm CP (10 pk)*	10
	MZ373-1602CPX		Q6143300080	MZ-Nozzle double pencil, 1.2 mm CP (10 pk)*	10
	MZ373-1603CPX		36143312300	MZ-Nozzle double pencil, 1.5 mm CP (10 pk)*	10
	MZ373-1604CPX		36143312310	MZ-Nozzle double pencil, 1.8 mm CP (10 pk)*	10
	MZ373-1605CPX		36143312311	MZ-Nozzle double pencil, 2.0 mm CP (10 pk)*	10
	MZ373-1607CPX		36143312320	MZ-Nozzle double pencil, 2.5 mm CP (10 pk)*	10
	MZ373-1608CPX		36143312330	MZ-Nozzle double pencil, 3.0 mm CP (10 pk)*	10
	MZ373-1609CPX		36143312340	MZ-Nozzle double pencil, 3.5 mm CP (10 pk)*	10
	MZ373-1610CPX		36143312350	MZ-Nozzle double pencil, 4.0 mm CP (10 pk)*	10
	MZ373-1611CPX		6143312360	MZ-Nozzle double pencil, 4.5 mm CP (10 pk)*	10
	MZ373-1612CPX		6143312370	MZ-Nozzle double pencil, 5.0 mm CP (10 pk)*	10
6	MZ373-1614CPX		Q6260700010	MZ-Nozzle double pencil, 4.0 mm/inner 1.2 mm CP (10 pk)*	10
	MZ373-1615CPX		6143355360	MZ-Nozzle double pencil, 4.0 mm/inner 1.4 mm CP (10 pk)*	10
	MZ373-1616CPX		6143355370	MZ-Nozzle double pencil, 4.0 mm/inner 1.8 mm CP (10 pk)*	10
	MZ373-1617CPX		06283301050	MZ-Nozzle double pencil, 4.5 mm/inner 1.2 mm CP (10 pk)*	10
	MZ373-1618CPX		06283301200	MZ-Nozzle double pencil, 5.0 mm/inner 1.2 mm CP (10 pk)*	10
	MZ373-1619CPX		06283301210	MZ-Nozzle double pencil, 5.5 mm/inner 1.2 mm CP (10 pk)*	10
	MZ373-1686CPX		06283301840	MZ-Nozzle double pencil, 5.5 mm/inner 2.0 mm CP (10 pk)*	10
	MZ373-1688X		06283302110	MZ-Nozzle double pencil, 7.0 mm/inner 1.8 mm CP (10 pk)*	10
7	MZ373-1572		Q6143300020	MZ-Nozzle double pencil SUS, 3.5 mm CP	1
	MZ373-1573		Q6143300030	MZ-Nozzle double pencil SUS, 4.0 mm CP	1
	MZ373-1574		Q6143300040	MZ-Nozzle double pencil SUS, 4.5 mm CP	1
8	MZ373-1820CPX		06283301820	MZ-Nozzle double pencil, 1.5 mm HP CP (10 pk)*	10
9	MZ373-1790CPX		06283301790	MZ-Nozzle pencil, 1.0 mm HP CP (10 pk)*	10
	MZ373-1800CPX		06283301800	MZ-Nozzle pencil, 1.2 mm HP CP (10 pk)*	10
	MZ373-1810CPX		06283301810	MZ-Nozzle pencil, 1.5 mm HP CP (10 pk)*	10
10	MZ373-0465		36143310523	MZ-Nozzle holder	1
11	MZ373-0030		Q6283300030	MZ-Nozzle double smooth, 6.0 mm	1
	MZ373-0020		Q6283300020	MZ-Nozzle double smooth, 7.5 mm	1
	MZ373-0010		Q6283300010	MZ-Nozzle double smooth, 9.5 mm	1

\*Parts available in single packs. To order single packs, remove the 'X' at the end of the part number (e.g. AM123-4567X would be AM123-4567).

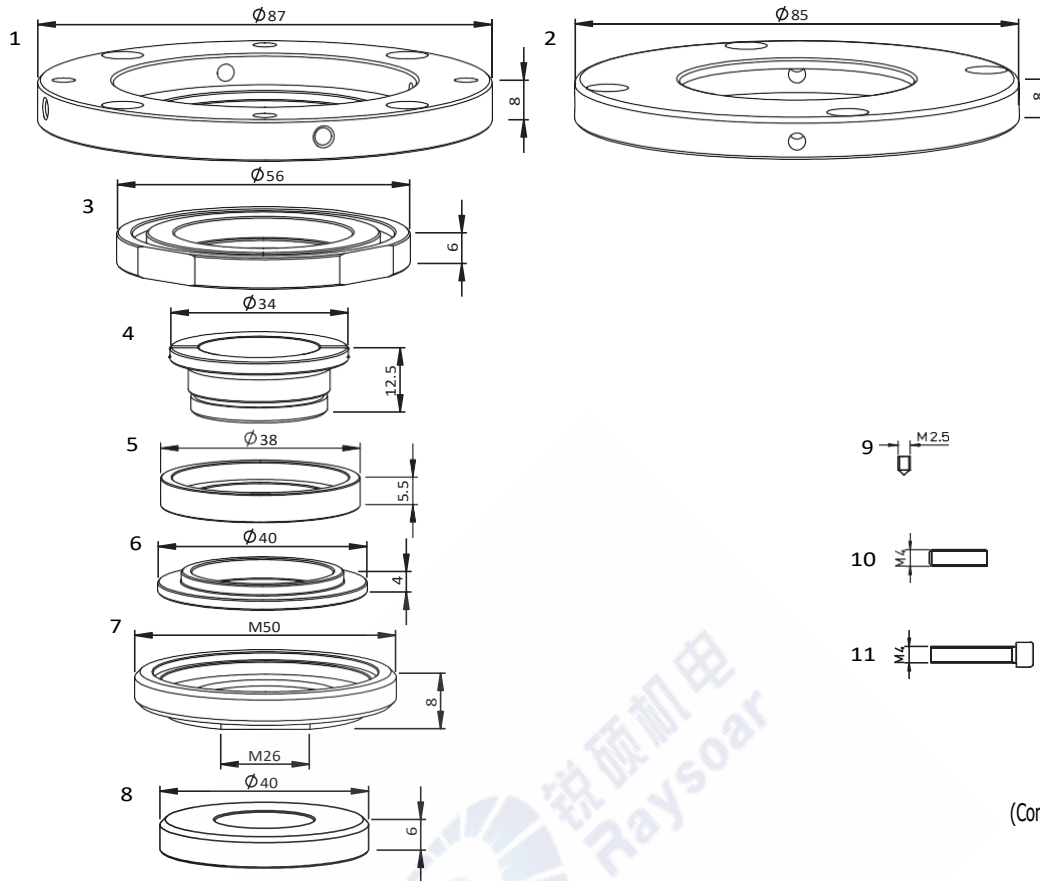

(Continued on next page)

**Consumables**

	Centricut P/N	Raysoar P/N	OEM Ref. No.	Description	Pkg qty
1	MZ413-0332		3614330332	MZ-Ring, aluminum	1
2	MZ413-0630		6283300630	MZ-Ring, aluminum	1
3	MZ413-0620		6283300620	MZ-Ring, brass	1
	MZ413-0320		46143300320	MZ-Ring, brass	1
4	MZ413-0280		46143300280, 46143300281	MZ-Retainer nut	1
5	MZ408-0270		46143300270	MZ-Ring, ceramic	1
	MZ413-0270		46143300270	MZ-Insulating, PTFE*	1
6	MZ408-0260		46143300260C	MZ-Ring, ceramic	1
	MZ413-0260		46143300260	MZ-Insulating, PTFE*	1
7	MZ413-0290		46143300290	MZ-Retainer nut	1
8	MZ408-4440		46143304440	MZ-Ring, ceramic	1
	MZ413-4440		46143304440	MZ-Insulating, PTFE*	1
9	MZ413-1180		46183301180	MZ-Screw	1
10	MZ413-0010			MZ-Screw (4 pcs)	4
11	MZ413-0200		A06CB040200, A06CB040160	MZ-Set screw (4 pcs)	4

Raysoar is not affiliated with the named manufacturers. Reference to machines, parts, descriptions, and model numbers are for convenience in verifying compatibility only. All parts are made by or for Centricut and are not made by the referenced manufacturers (unless expressly indicated). All other trademarks are the properties of their respective owners. Raysoar is the authorized distributor of Centricut.

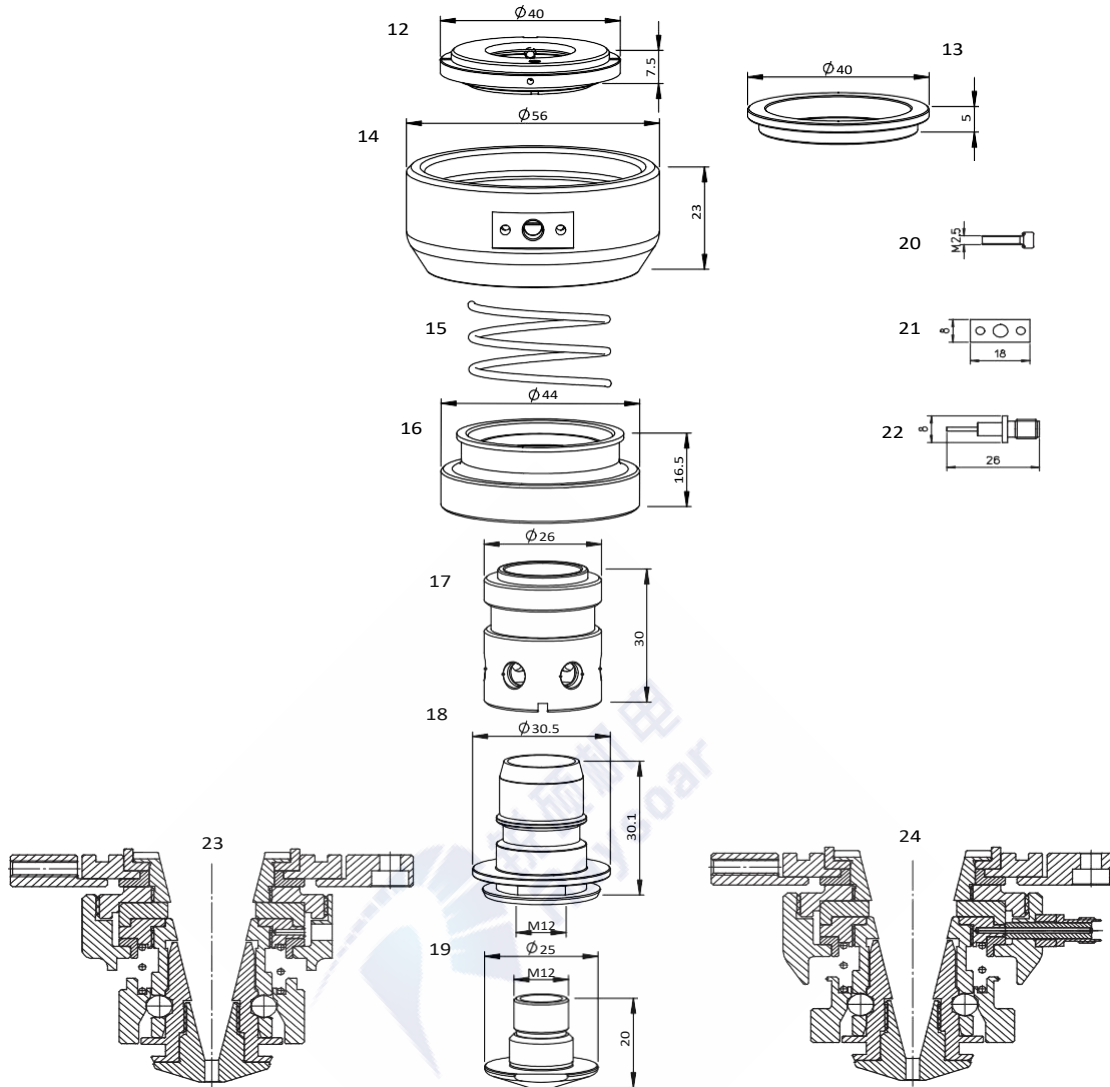
**Consumables**

	Centricut P/N	Raysoar P/N	OEM Ref. No.	Description	Pkg qty
12	MZ413-7420		46143307420, 46143307421	MZ-Retainer nut	1
13	MZ408-0240		46143300240	MZ-Ring, ceramic	1
	MZ413-0240		46143300240T	MZ-Insulating, PTFE*	1
14	MZ413-7980		36143307980	MZ-Body, aluminum	1
15	MZ413-0220		46143300220	MZ-Spring	1
16	MZ413-8000		46143308000	MZ-Spring retainer, steel	1
17	MZ413-4400		36143304400, 36143304401	MZ-Coupler	1
	MZ413-0230 (not shown)		46143300230	MZ-Ball kit replacement (6 pcs)	1
18	MZ368-0001		36143304420	MZ-Nozzle holder Hyper Gear	1
19	Please refer to the Mazak® nozzle section				
20	MZ413-0030		46603300030, A05GS002560	MZ-Screw	1
21	MZ413-8170		46143308170	MZ-Spacer	1
22	MZ413-8190		46143308190	MZ-Connector	1
23	MZ413-0001			MZ-Complete head (ceramic insulating)	1
24	MZ413-0002			MZ-Complete head (ceramic insulating)	1

\*PolyTetraFluoroEthylene is a fluorocarbon-based polymer and is commonly abbreviated PTFE. The Teflon® brand of PTFE is manufactured only by DuPont and is not sold by Hypertherm. Hypertherm purchases other brands of PTFE from various high quality manufacturers.

Raysoar is not affiliated with the named manufacturers. Reference to machines, parts, descriptions, and model numbers are for convenience in verifying compatibility only. All parts are made by or for Centricut and are not made by the referenced manufacturers (unless expressly indicated). All other trademarks are the properties of their respective owners. Raysoar is the authorized distributor of Centricut.

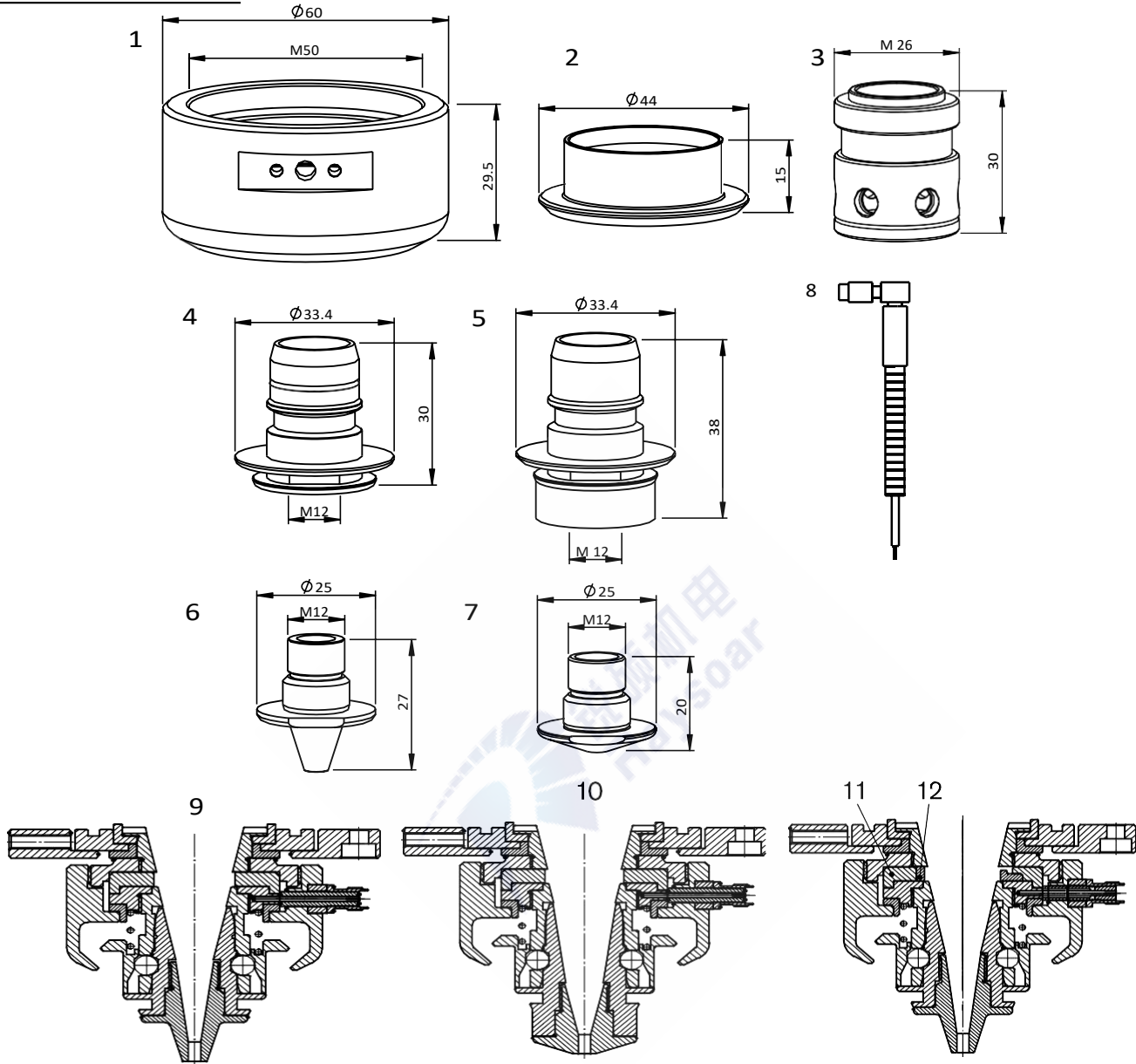
**HyperGear – PFP torch**

**Consumables**

	Centricut P/N	Raysoar P/N	OEM Ref. No.	Description	Pkg qty
1	MZ368-0550		36143310550	MZ-Body, aluminum	1
2	MZ368-0541		36143310541, 36143310542	MZ-Retainer, steel	1
3	MZ368-0530		36143310530, 36143310531	MZ-Coupler	1
4	MZ368-0522		36143310522E, 36143310522, 36143310523	MZ-Nozzle holder	1
5	MZ368-0740		36143310740	MZ-Nozzle holder	1
6	Please refer to the Mazak® slim nozzle section				
7	Please refer to the Mazak® nozzle section				
8	MZ335-8290		46143308290	MZ-Sensor cable, 75 mm (3")	1
9	MZ368-0060			MZ-Head w/ceramic spacer	1
10	MZ368-0070			MZ-Head w/ceramic spacer	1
11/12	MZ368-2180		46143312180	MZ-Ring, 23x4 ceramic	1
	MZ368-2170		46143312170	MZ-Ring 40x6, PPS	1

Raysoar is not affiliated with the named manufacturers. Reference to machines, parts, descriptions, and model numbers are for convenience in verifying compatibility only. All parts are made by or for Centricut and are not made by the referenced manufacturers (unless expressly indicated). All other trademarks are the properties of their respective owners. Raysoar is the authorized distributor of Centricut.

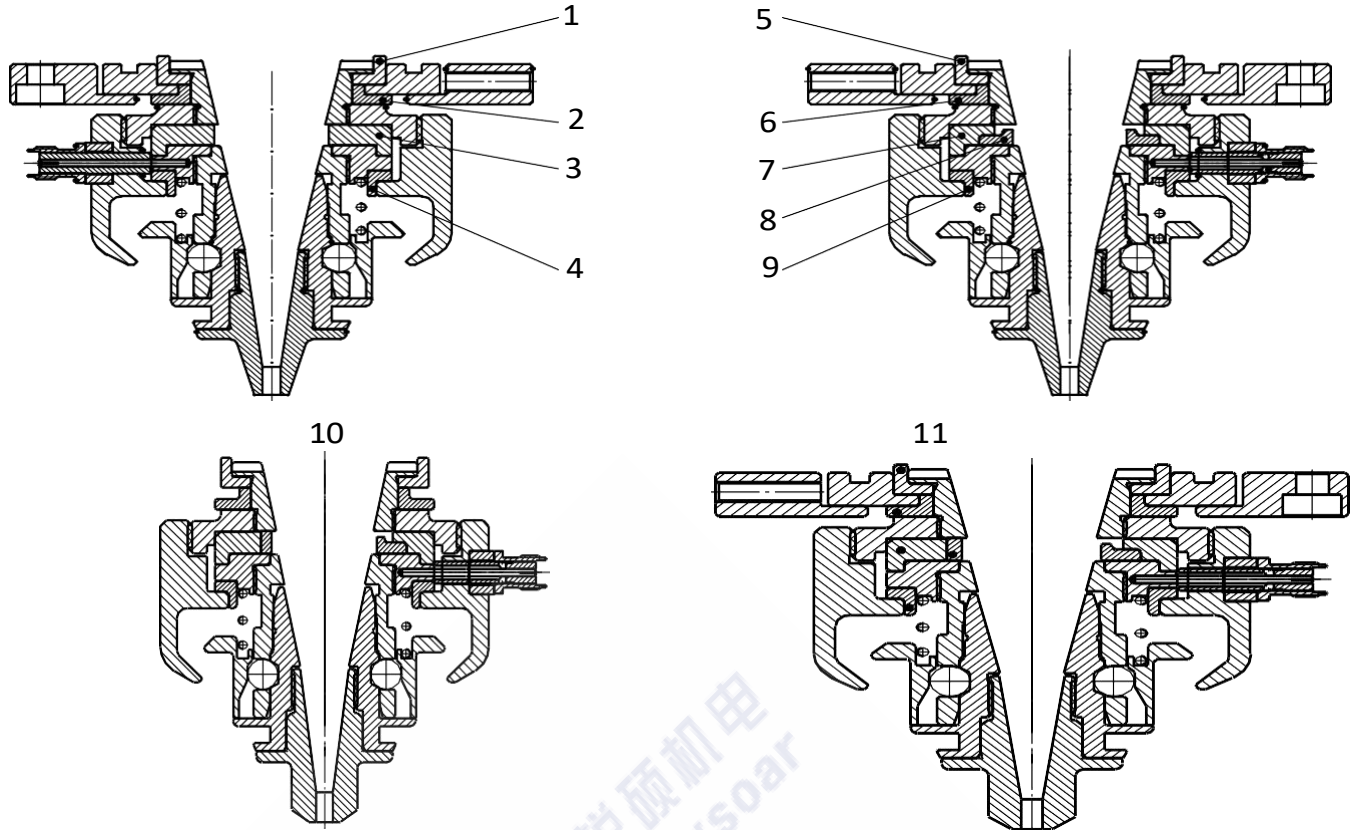

**Consumables**

	Centricut P/N	Raysoar P/N	OEM Ref. No.	Description	Pkg qty
1	MZ408-0270		46143300270	MZ-Ring, ceramic	1
	MZ413-0270		46143300270	MZ-Insulating, PTFE*	1
2	MZ408-0260		46143300260C	MZ-Ring, ceramic	1
	MZ413-0260		46143300260	MZ-Insulating, PTFE*	1
3	MZ408-4440		46143304440	MZ-Ring, ceramic	1
	MZ413-4440		46143304440	MZ-Insulating, PTFE*	1
4	MZ408-0240		46143300240	MZ-Ring, ceramic	1
	MZ413-0240		46143300240T	MZ-Insulating, PTFE*	1
5	MZ368-2100		46143312100, 46143312101	MZ-Insulating ring, 38x5.5 PPS	1
6	MZ368-2130		46143312130	MZ-Insulating ring, 40x4 PPS	1
7	MZ368-2080		46143312080	MZ-Spacer 40x6, PPS	1
8	MZ368-2090		46143312090	MZ-Ring, 30x3 ceramic	1
9	MZ368-2120		46143312120	MZ-Insulating ring, 40x5 PPS	1
10	MZ368-0085		TMA85	MZ-Head w/PPS spacer	1
11	MZ368-0080		TMA80	MZ-Head w/PPS spacer	1

\*PolyTetraFluoroEthylene is a fluorocarbon-based polymer and is commonly abbreviated PTFE. The Teflon® brand of PTFE is manufactured only by DuPont and is not sold by Hypertherm. Hypertherm purchases other brands of PTFE from various high quality manufacturers.

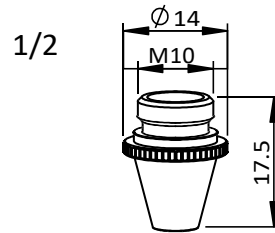

## Consumables

	Centricut P/N	Raysoar P/N	OEM Ref. No.	Description	Pkg qty
1	MZ322-0008X		46603350508	MZ-Nozzle, 0.8 mm (10 pk)	10
	MZ322-0511-1.0		46603350511	MZ-Nozzle, 1.0 mm	1
	MZ322-0511X		46603350511	MZ-Nozzle, 1.0 mm (10 pk)	10
	MZ322-0512-1.2		46603350512	MZ-Nozzle, 1.2 mm	1
	MZ322-0512X		46603350512	MZ-Nozzle, 1.2 mm (10 pk)	10
	MZ322-0520-1.5		4660335052B	MZ-Nozzle, 1.5 mm	1
	PT322-0520X		4660335052B	PT-Nozzle, 1.5 mm (10 pk)	10
	MZ322-1517X		46603350517	MZ-Nozzle, 1.7 mm (10 pk)	10
	MZ322-0517X		46603350517-1,8	MZ-Nozzle, 1.8 mm (10 pk)*	10
	MZ322-0522-2.0		4660335052C	MZ-Nozzle, 2.0 mm	1
	MZ322-0522X		4660335052C	MZ-Nozzle, 2.0 mm (10 pk)	10
	MZ322-0022X		46603350522-2,2	MZ-Nozzle, 2.2 mm (10 pk)*	10
	MZ322-0525-2.5		46603350525	MZ-Nozzle, 2.5 mm	1
	MZ322-0025X		46603350525	MZ-Nozzle, 2.5 mm (10 pk)	10
	MZ322-0530-3.0		46603350530	MZ-Nozzle, 3.0 mm	1
	MZ322-0030X		46603350530	MZ-Nozzle, 3.0 mm (10 pk)	10
	MZ322-0530-3.5		46603350530-3,5	MZ-Nozzle, 3.5 mm	1
	MZ322-1035X		46603350530-3,5	MZ-Nozzle, 3.5 mm (10 pk)	10
	MZ322-0530-4.0		46603350530-4,0	MZ-Nozzle, 4.0 mm	1
	MZ322-1040X		46603350530-4,0	MZ-Nozzle, 4.0 mm (10 pk)	10
2	MZ322-0512CPX		46603350512	MZ-Nozzle, 1.2 mm CP (10 pk)*	10
	PT322-0520CPX		4660335052B	PT-Nozzle, 1.5 mm CP (10 pk)*	10
	MZ322-0517CP		46603350517-1,8	MZ-Nozzle, 1.8 mm CP	1
	MZ322-0522CPX		4660335052C	MZ-Nozzle, 1.8 mm CP (10 pk)*	10
	MZ322-0025CPX		46603350525	MZ-Nozzle, 2.5 mm CP (10 pk)*	10
	MZ322-0030CPX		46603350530	MZ-Nozzle, 3.0 mm CP (10 pk)*	10

\*Available in single packs. To order single packs, remove the 'X' at the end of the part number (e.g. AM123-4567X would be AM123-4567).



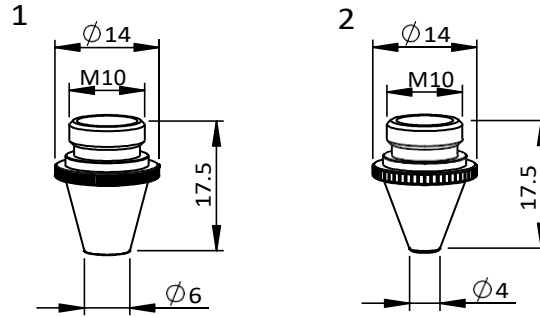

## Consumables 易损件

	Centricut P/N	Raysoar P/N	OEM Ref. No.	Description	Pkg qty
1	MZ346-0002X			MZ-Nozzle double, 1.2 mm (10 pk)*	10
	MZ346-0003X		46683302400	MZ-Nozzle double, 1.5 mm (10 pk)*	10
	MZ346-0005X			MZ-Nozzle double, 1.8 mm (10 pk)	10
	MZ346-0006X		46683302390	MZ-Nozzle double, 2.0 mm (10 pk)*	10
	MZ346-0008X		46683302400	MZ-Nozzle double, 2.5 mm (10 pk)*	10
	MZ346-0009X		46683302410	MZ-Nozzle double, 3.0 mm (10 pk)*	10
	MZ346-0002CPX			MZ-Nozzle double, 1.2 mm CP (10 pk)*	10
	MZ346-0003CPX		46683302380	MZ-Nozzle double, 1.5 mm CP (10 pk)*	10
	MZ346-0004CPX			MZ-Nozzle double, 1.7 mm CP (10 pk)	10
	MZ346-0006CPX		46683302390	MZ-Nozzle double, 2.0 mm CP (10 pk)*	10
	MZ346-0007CPX			MZ-Nozzle double, 2.2 mm CP (10 pk)	10
	MZ346-0008CPX		46683302400	MZ-Nozzle double, 2.5 mm CP (10 pk)*	10
	MZ346-0009CPX		46683302410	MZ-Nozzle double, 3.0 mm CP (10 pk)*	10
	2	MZ321-0521-1.0		46603350521	MZ-Nozzle, 1.0 mm
MZ321-0010X			46603350521	MZ-Nozzle, 1.0 mm (10 pk)	10
MZ321-0521-1.2			46603350521	MZ-Nozzle, 1.2 mm	1
MZ321-0012X			46603350521	MZ-Nozzle, 1.2 mm (10 pk)	10
MZ321-0520-1.5			46603350520	MZ-Nozzle, 1.5 mm	1
MZ321-0520X			46603350520	MZ-Nozzle, 1.5 mm (10 pk)	10
M321-0521-1.7			46603350521	MZ-Nozzle, 1.7 mm	1
MZ321-0017X			46603350521	MZ-Nozzle, 1.7 mm (10 pk)	10
MZ321-0522-2.0			46603350522, 46683301721	MZ-Nozzle, 2.0 mm	1
MZ321-0054X			46603350522	MZ-Nozzle, 2.0 mm (10 pk)	10
MZ321-0522-2.5			46603350522	MZ-Nozzle, 2.5 mm	1
MZ321-1025X			46603350522	MZ-Nozzle, 2.5 mm (10 pk)	10
MZ321-0522-3.0			46683301281	MZ-Nozzle, 3.0 mm	1
MZ321-1030X			46683301281	MZ-Nozzle, 3.0 mm (10 pk)	10
MZ321-0010CPX			46603350521	MZ-Nozzle, 1.0 mm CP (10 pk)	10
MZ321-0012CPX			46603350521	MZ-Nozzle, 1.2 mm CP (10 pk)	10
MZ321-520-1.5CP			46603350520	MZ-Nozzle, 1.5 mm CP	1
MZ321-0520CPX			46603350520	MZ-Nozzle, 1.5 mm CP (10 pk)	10
MZ321-522-2.0CP			46603350522	MZ-Nozzle, 2.0 mm CP	1
MZ321-0054CPX			46603350522	MZ-Nozzle, 2.0 mm CP (10 pk)	10
MZ321-522-2.5CP			46603350522	MZ-Nozzle, 2.5 mm CP	1
MZ321-1025CPX			46603350522	MZ-Nozzle, 2.5 mm CP (10 pk)	10
MZ321-1030CPX			46683301281	MZ-Nozzle, 3.0 mm CP (10 pk)	10

\*Centricut parts available in single packs. To order single packs, remove the 'X' at the end of the part number (e.g. AM123-4567X would be AM123-4567).

1-3

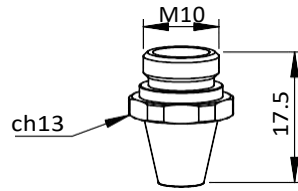

## Consumables

	Centricut P/N	Raysoar P/N	OEM Ref. No.	Description	Pkg qty
1	MZ385-0511X		46603350511	MZ-Nozzle hexagonal, 1.0 mm (10 pk)*	10
	MZ385-5052X		4660335052A	MZ-Nozzle hexagonal, 1.2 mm (10 pk)*	10
	MZ385-5052BX		4660335052B	MZ-Nozzle hexagonal, 1.5 mm (10 pk)*	10
	MZ385-0517X		46603350517	MZ-Nozzle hexagonal, 1.7 mm (10 pk)*	10
	MZ385-517X		46603350517-1,8	MZ-Nozzle hexagonal, 1.8 mm (10 pk)	10
	MZ385-5052CX		4660335052C	MZ-Nozzle hexagonal, 2.0 mm (10 pk)*	10
	MZ385-0522X		46603350522-2,2	MZ-Nozzle hexagonal, 2.2 mm (10 pk)	10
	MZ385-0003X		4660335052D	MZ-Nozzle hexagonal, 2.5 mm (10 pk)*	10
	MZ385-1003X		46603350530	MZ-Nozzle hexagonal, 3.0 mm (10 pk)	10
	MZ385-0530X		46603350530-4,0	MZ-Nozzle hexagonal, 4.0 mm (10 pk)	10
2	MZ385-0511CPX		46603350511	MZ-Nozzle hexagonal, 1.0 mm CP (10 pk)*	10
	MZ385-5052CPX		4660335052A	MZ-Nozzle hexagonal, 1.2 mm CP (10 pk)	10
	MZ385-052CPX		4660335052B	MZ-Nozzle hexagonal, 1.5 mm CP (10 pk)*	10
	MZ385-0052CPX		4660335052C	MZ-Nozzle hexagonal, 2.0 mm CP (10 pk)*	10
	MZ385-0003CPX		4660335052D	MZ-Nozzle hexagonal, 2.5 mm CP (10 pk)	10
	MZ385-1003CPX		46603350530	MZ-Nozzle hexagonal, 3.0 mm CP (10 pk)	10
	MZ385-0530CPX		46603350530-4,0	MZ-Nozzle hexagonal, 4.0 mm CP (10 pk)	10
3	MZ419-0001X			MZ-Nozzle double hexagonal, 1.2 mm (10 pk)	10
	MZ419-0002X			MZ-Nozzle double hexagonal, 1.5 mm (10 pk)*	10
	MZ419-0003X			MZ-Nozzle double hexagonal, 1.8 mm (10 pk)	10
	MZ419-0004X			MZ-Nozzle double hexagonal, 2.0 mm (10 pk)	10
	MZ419-0005X			MZ-Nozzle double hexagonal, 2.2 mm (10 pk)	10
	MZ419-0006X			MZ-Nozzle double hexagonal, 2.5 mm (10 pk)	10
	MZ419-0001CPX			MZ-Nozzle double hexagonal, 1.2 mm CP (10 pk)	10
	MZ419-0002CPX			MZ-Nozzle double hexagonal, 1.5 mm CP (10 pk)	10
	MZ419-0004CPX			MZ-Nozzle double hexagonal, 2.0 mm CP (10 pk)	10
	MZ419-0006CPX			MZ-Nozzle double hexagonal, 2.5 mm CP (10 pk)	10
	MZ419-0007CPX			MZ-Nozzle double hexagonal, 3.0 mm CP (10 pk)	10

\*Parts available in single packs. To order single packs, remove the 'X' at the end of the part number (e.g. AM123-4567X would be AM123-4567).

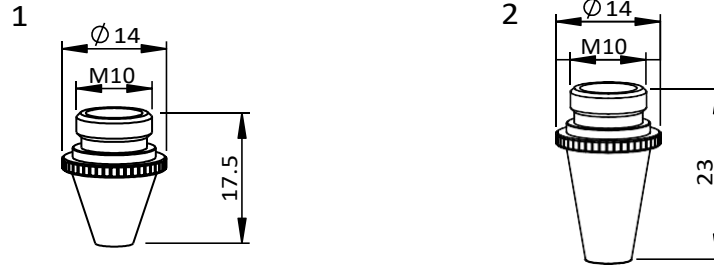

## Consumables 易损件

	Centricut P/N	Raysoar P/N	OEM Ref. No.	Description	Pkg qty
1	MZ322-0523		46603350523	MZ-Nozzle shower, 1.0 mm	1
	MZ322-0523-1.5			MZ-Nozzle shower, 1.5 mm	1
	MZ322-0523-2.0			MZ-Nozzle shower, 2.0 mm	1
2	MZ322-0001			MZ-Nozzle long, 2.0 mm	1

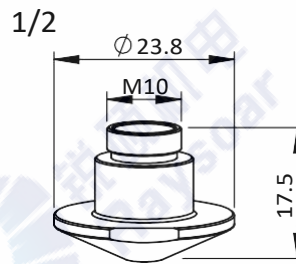

## Consumables

	Centricut P/N	Raysoar P/N	OEM Ref. No.	Description	Pkg qty	
1	MZ335-0004			MZ-Nozzle, 1.0 mm	1	
	MZ335-0011			MZ-Nozzle, 1.2 mm	1	
	MZ335-1950		46683301950	MZ-Nozzle, 1.5 mm	1	
	MZ335-1821		46683301821	MZ-Nozzle, 2.0 mm	1	
	MZ335-1960		46683301960	MZ-Nozzle, 2.5 mm	1	
	MZ335-1970		46683301970	MZ-Nozzle, 3.0 mm	1	
	MZ335-0006			MZ-Nozzle, 3.5 mm	1	
	MZ335-0013			MZ-Nozzle, 4.0 mm	1	
	MZ335-1950CP		46683301950	MZ-Nozzle, 1.5 mm CP	1	
	MZ335-1821CP		46683301821	MZ-Nozzle, 2.0 mm CP	1	
	MZ335-1960CP		46683301960	MZ-Nozzle, 2.5 mm CP	1	
	MZ335-1970CP		46683301970	MZ-Nozzle, 3.0 mm CP	1	
	2	MZ360-0002			MZ-Nozzle double, 1.2 mm	1
		MZ360-0003		46683302420	MZ-Nozzle double, 1.5 mm	1
MZ360-0005			46683302430	MZ-Nozzle double, 2.0 mm	1	
MZ360-0007				MZ-Nozzle double, 2.5 mm	1	
MZ360-0008			46683302450	MZ-Nozzle double, 3.0 mm	1	
MZ360-0003CP			46683302420	MZ-Nozzle double, 1.5 mm CP	1	
MZ360-0005CP			46683302430	MZ-Nozzle double, 2.0 mm CP	1	
MZ360-0008CP				MZ-Nozzle double, 3.0 mm CP	1	

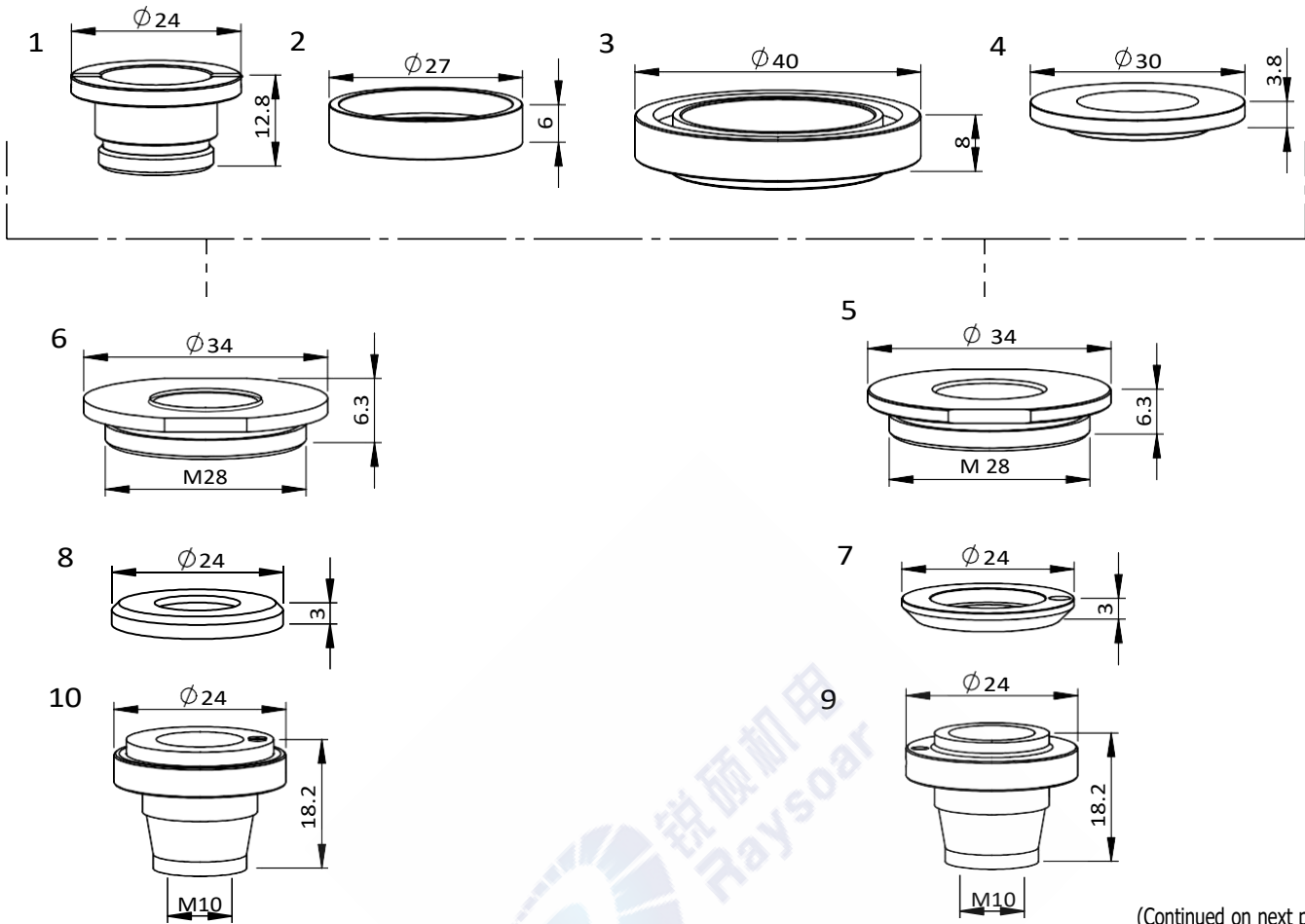

(Continued on next page)

## Consumables

	Centricut P/N	Raysoar P/N	OEM Ref. No.	Description	Pkg qty
1	MZ335-1110		46683301110, 46773300500	MZ-Bracket, copper	1
2	MZ335-1080		46683301090, 46683302081	MZ-Spacer 27x5.5, PTFE*	1
	MZ335-1080P		46683301090, 46683302081	MZ-Ring, plastic	1
	MZ335-1080C		46683301090, 46683302081	MZ-Ring, ceramic	1
	MZ335-1080M		46683301080, 46683302081	MZ-Spacer 27x5.5, ceramic	1
	MZ309-3200 (not shown)			MZ-O-ring external base	1
3	MZ335-1070		46683301070	MZ-Base, brass	1
4	MZ335-1090		46683301090, 46683302091	MZ-Spacer 30x4, PTFE*	1
	MZ335-0090C		46683301090, 46683302091	MZ-Spacer 30x4, special	1
	MZ335-1090C		46683301090, 46683302091	MZ-Ring, ceramic	1
	MZ335-1090M		46683301090, 46683302091	MZ-Spacer 30x4, ceramic	1
5	MZ335-1101		46773300510	MZ-Nut, copper	1
6	MZ335-1100		46683301100	MZ-Bracket, copper	1
7	MZ335-1120		46683301120	MZ-Spacer 24x3, PTFE*	1
	MZ335-1120LL		46683301120	MZ-Ring long life	1
	MZ335-1120C		46683301120	MZ-Ring, ceramic	1
8	MZ335-0710		46677330710	MZ-Ring, ceramic	1
	MZ335-0710M		46773300710	MZ-Spacer 24x3, ceramic	1
9	MZ335-0850		46683300850	MZ-Nozzle body, copper	1
10	MZ335-0720		46773300720, 46773300721, 46683300720	MZ-Nozzle body, copper	1

Raysoar is not affiliated with the named manufacturers. Reference to machines, parts, descriptions, and model numbers are for convenience in verifying compatibility only. All parts are made by or for Centricut and are not made by the referenced manufacturers (unless expressly indicated). All other trademarks are the properties of their respective owners. Raysoar is the authorized distributor of Centricut.

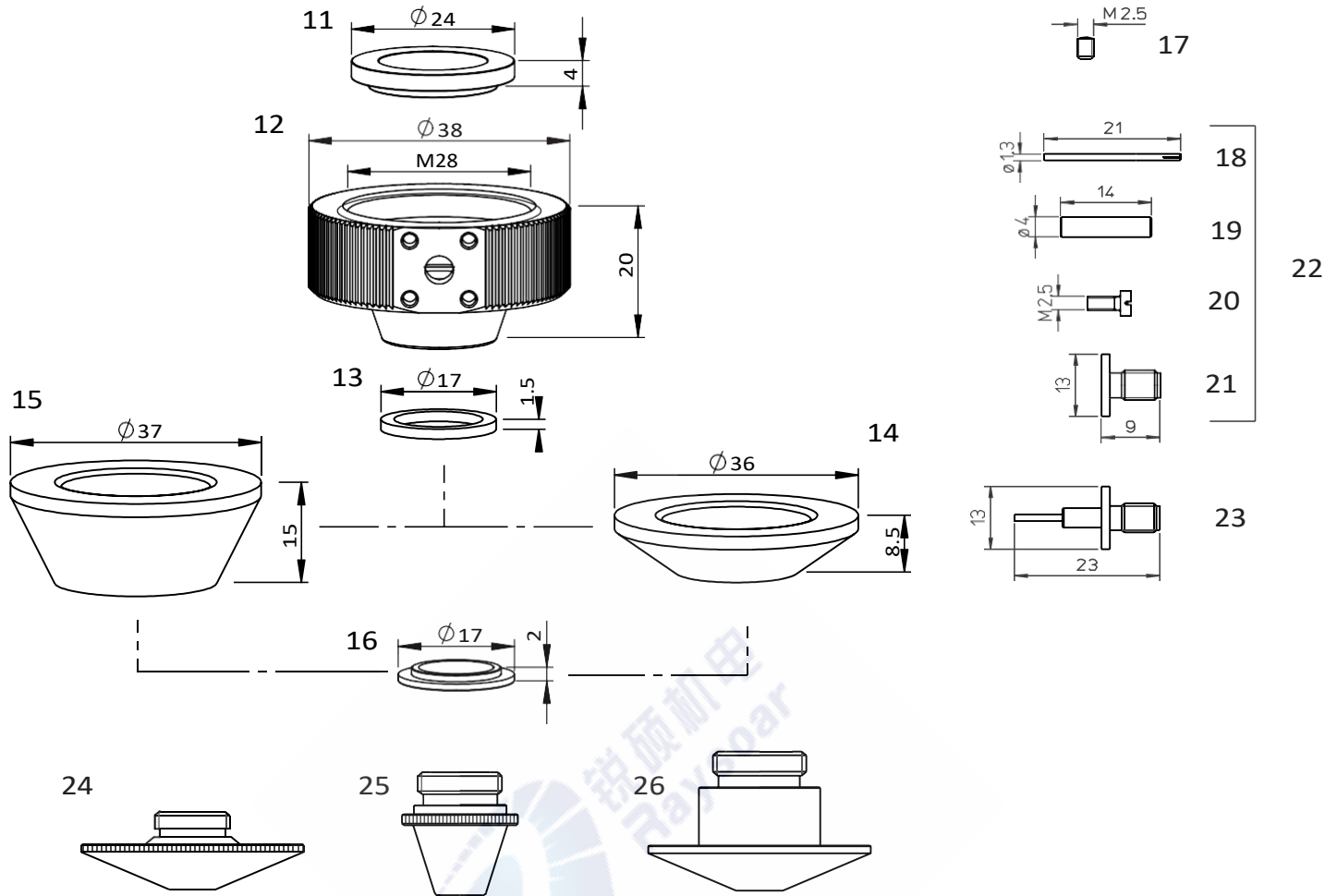
**Consumables**

	Centricut P/N	Raysoar P/N	OEM Ref. No.	Description	Pkg qty
11	MZ335-1130		46683301130, 46683302111	MZ-Spacer 24x4, PTFE*	1
	MZ335-1130LL		46683301130	MZ-Ring long life	1
	MZ335-1130C		46683301130	MZ-Spacer, ceramic	1
	MZ335-1130M		46683301130	MZ-Spacer 24x4, ceramic	1
12	MZ335-1140		46683301140, 36773300530	MZ-Housing, aluminum	1
13	MZ335-1150		46683301150	MZ-Spacer 17x1.5, PTFE*	1
14	MZ335-1930		46683301930	MZ-Nozzle body cover	1
	MZ335-1930LL		46683301930P	MZ-Nozzle body cover, long life	1
	MZ335-0009		46683301930C	MZ-Protective cover, ceramic	1
15	MZ335-1841		46683301841	MZ-Nozzle cover	1
16	MZ335-1160		46683301160	MZ-Ring, 17x2, copper	1
17	MZ335-1180		46683301180	MZ-Bolt	1
18	MZ335-1170		46683301170	MZ-Contact	1
19	MZ335-0030		46683300030	MZ-Connecting pipe, PTFE *	1
20	MZ335-0000		46683300000	MZ-Screws for connector kit MZ335-0001 (4 pcs)	4
21	MZ335-1113		46683301170	MZ-Connector	1
22	MZ335-0001		46683301171, 46683301170, not assembled	MZ-Connector kit	1
23	MZ335-0001A		46683301171, 46683301170	MZ-Connector kit, assembled	1
24	Please refer to the Trumpf® nozzle section				
25	Please refer to the Mazak® nozzle section				
26	Please refer to the Mazak® nozzle section				

\*PolyTetraFluoroEthylene is a fluorocarbon-based polymer and is commonly abbreviated PTFE. The Teflon® brand of PTFE is manufactured only by DuPont and is not sold by Hypertherm. Hypertherm purchases other brands of PTFE from various high quality manufacturers.

Raysoar is not affiliated with the named manufacturers. Reference to machines, parts, descriptions, and model numbers are for convenience in verifying compatibility only. All parts are made by or for Centricut and are not made by the referenced manufacturers (unless expressly indicated). All other trademarks are the properties of their respective owners. Raysoar is the authorized distributor of Centricut.

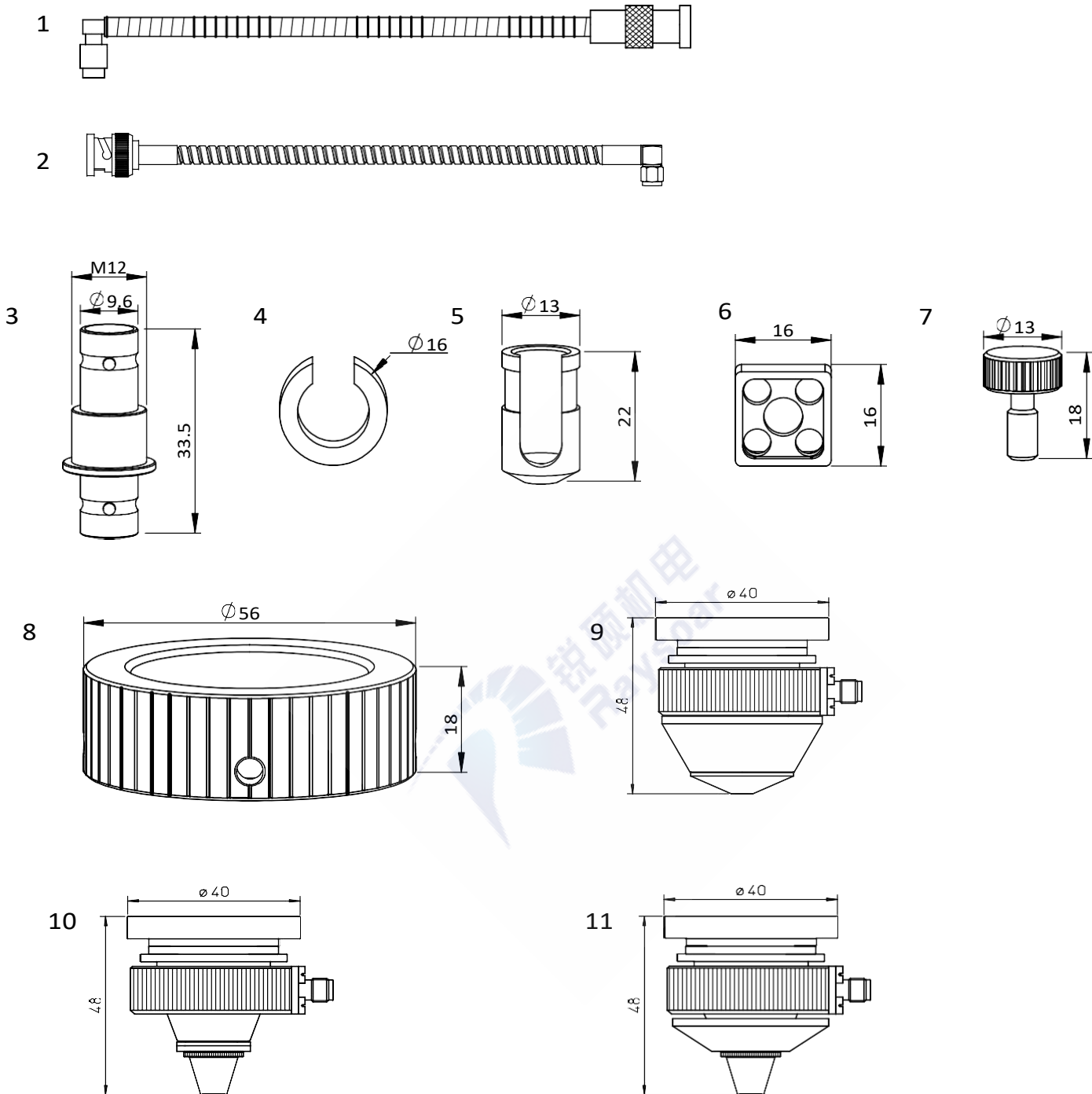
**Consumables**

	Centricut P/N	Raysoar P/N	OEM Ref. No.	Description	Pkg qty
1	MZ335-1980		46683301980, 46683301982	MZ-Sensor head connecting cable, short 280 mm (11")	1
	MZ335-1330		46683301330	MZ-Sensor head connecting cable, long 310 mm (12")	1
2	MZ335-1330A		46683301330	MZ-Sensor cable, 305 mm (12") armored	1
	MZ335-1980A		46683301980, 46683301982	MZ-Sensor cable, 280 mm (11") armored	1
3	MZ335-0005			MZ-Connecting cable adapter	1
4	MZ335-1870		46683301870, 46683301920	MZ-Cover clips	1



## Consumables

	Centricut P/N	Raysoar P/N	OEM Ref. No.	Description	Pkg qty
5	MZ335-1860		46683301860, 46683301910	MZ-Cable connector cover	1
	MZ335-1860LL		46683301860	MZ-Connector cover, long life	1
6	MZ335-1850		46683301851	MZ-Connector cover	1
	MZ335-1850P		46683301850, 46683301851	MZ-Cover, plastic	1
7	MZ335-0320		46683300032, 46603300032	MZ-Bolt M5 x 0.5	1
8	MZ335-0930		46683300930	MZ-Ring	1
9	MZ335-0002			MZ-Head w/PTFE* spacer	1
	MZ335-1013			MZ-Head w/ceramic spacer	1
	MZ335-0012			MZ-Head w/long life spacer	1
10	MZ335-1014			MZ-Head w/PTFE* spacer	1
	MZ335-0015			MZ-Head w/long life spacer	1
	MZ335-0016			MZ-Head w/ceramic spacer	1
11	MZ335-0017			MZ-Head w/PTFE spacer	1
	MZ335-0018			MZ-Head w/long life spacer	1
	MZ335-0019			MZ-Head w/ceramic spacer	1

\*PolyTetraFluoroEthylene is a fluorocarbon-based polymer and is commonly abbreviated PTFE. The Teflon® brand of PTFE is manufactured only by DuPont and is not sold by Hypertherm. Hypertherm purchases other brands of PTFE from various high quality manufacturers.



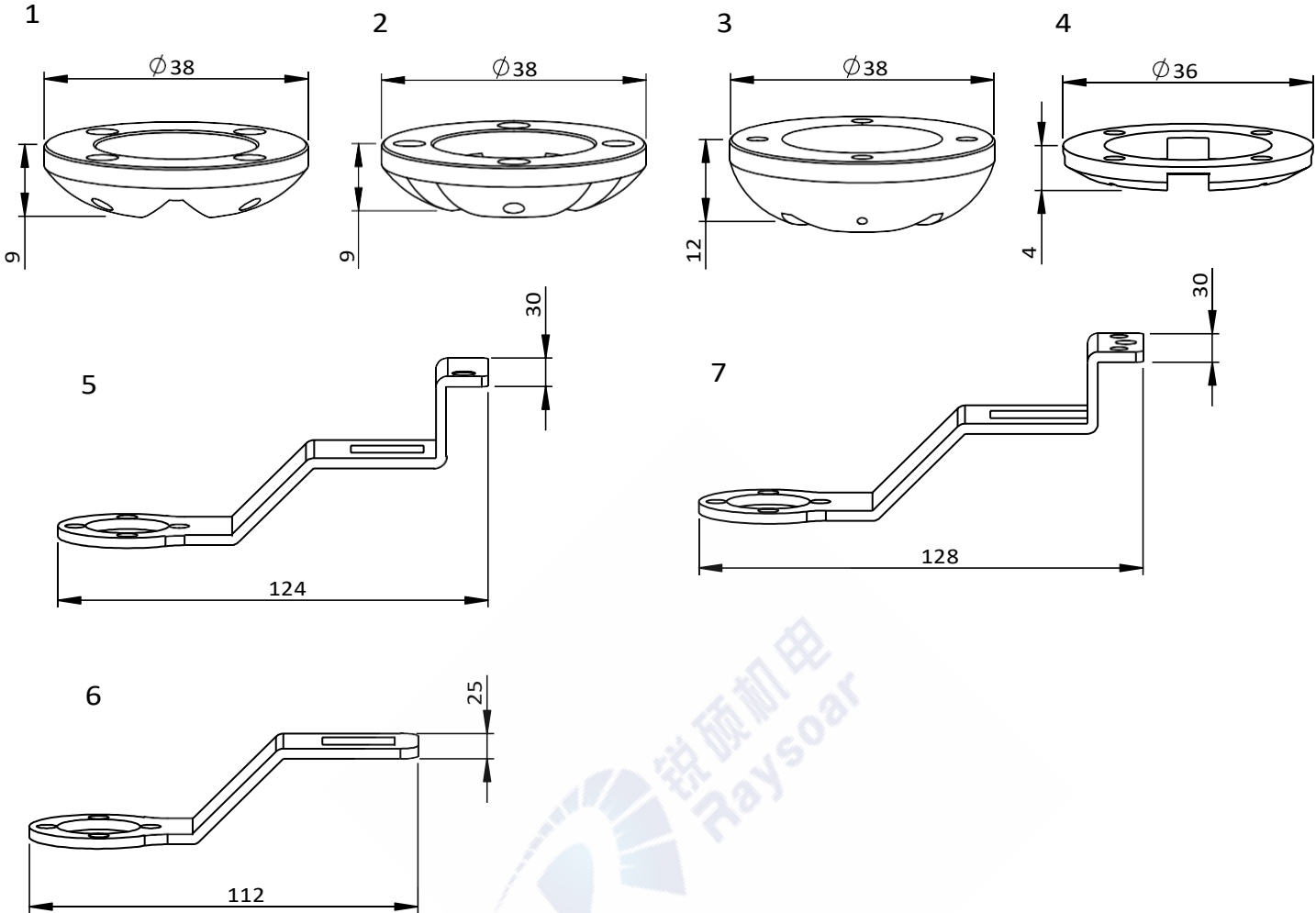

**Consumables**

	Centricut P/N	Raysoar P/N	OEM Ref. No.	Description	Pkg qty
1	MZ309-5080		46602350080	MZ-Stylus foot H9, brass	1
	MZ309-1043		46572301043	MZ-Stylus foot H9, steel	1
	MZ309-1045		46572301045	MZ-Stylus foot H9, PTFE*	1
2	MZ309-0001			MZ-Stylus foot H9, brass	1
3	MZ309-1041		46572301041, 46602350070	MZ-Stylus foot H12, brass	1
	MZ309-1042		46572301042, 46572301041S	MZ-Stylus foot H12, steel	1
	MZ309-1041T		46572301041T	MZ-Stylus foot H12, PTFE*	1
4	MZ309-0520		46512300520	MZ-Stylus foot H4, brass	1
5	MZ309-0580		36602300580	MZ-Stylus arm w/screw M6	1
6	MZ309-0560		36602300560, 36682300050	MZ-Stylus arm	1
7	MZ309-0281		36682300281	MZ-Stylus arm w/screw M6 and M5	1
	MZ309-001 (not shown)		68057488	MZ-Screws for stylus feet (10 pcs)	10

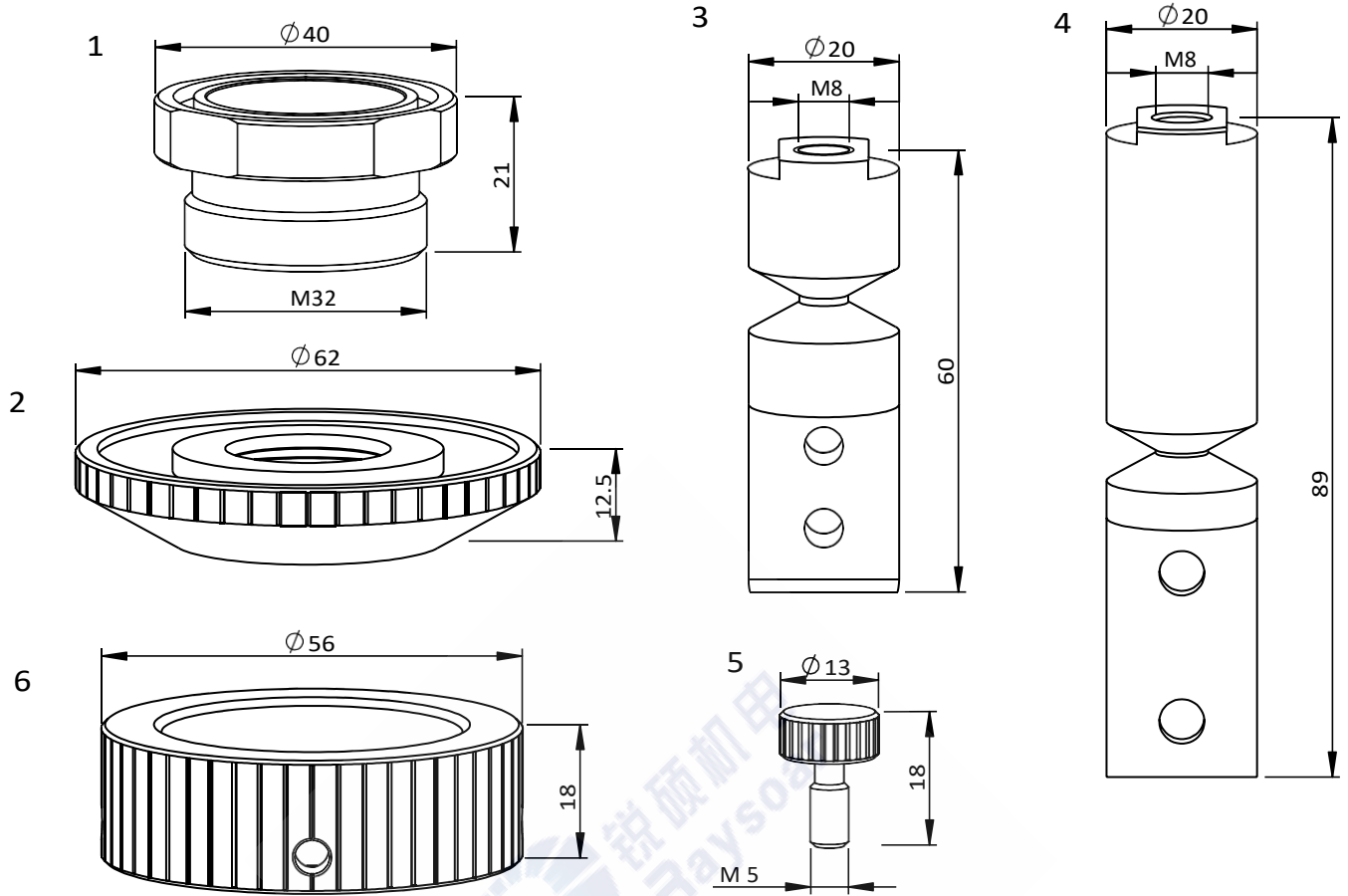
\*PolyTetraFluoroEthylene is a fluorocarbon-based polymer and is commonly abbreviated PTFE. The Teflon® brand of PTFE is manufactured only by DuPont and is not sold by Hypertherm. Hypertherm purchases other brands of PTFE from various high quality manufacturers.

**Consumables**

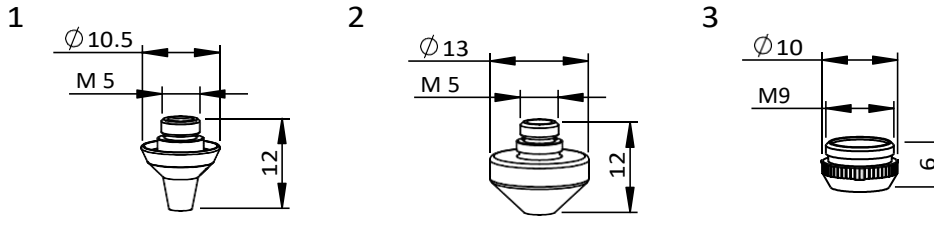
	Centricut P/N	Raysoar P/N	OEM Ref. No.	Description	Pkg qty
1	MZ309-0080		46523300080	MZ-Base	1
	MZ309-3200 (not shown)			MZ-O-ring external base	1
	MZ309-2200 (not shown)			MZ-O-ring internal base	1
2	MZ309-0030		46683300030	MZ-Retainer	1
3	MZ309-0280		36682300280, 36673300280	MZ-Breakaway bar L60-M8	1
4	MZ309-0550		36602300230	MZ-Breakaway bar L89-M8	1
5	MZ335-0320		46683300032, 46603300032	MZ-Bolt M5 x 0.5	1
6	MZ335-0930		46683300930	MZ-Ring	1



Consumables 易损件

	Centricut P/N	Raysoar P/N	OEM Ref. No.	Description	Pkg qty
1	PT347-0005X		46713300290-10	PT-Nozzle 3D, 1.0 mm (10 pk)*	10
	PT347-0290-1.2		46713300290-12	PT-Nozzle 3D, 1.2 mm	1
	PT347-0090X		46713300290-12	PT-Nozzle 3D, 1.2 mm (10 pk)	10
	PT347-0290X		46713300290-15, P0352-381-00015	PT-Nozzle 3D, 1.5 mm (10 pk)*	10
	PT347-0118X		P0352-377-00018	PT-Nozzle 3D, 1.8 mm (10 pk)	10
	PT347-0280X		46713300310, P0352-382-00020	PT-Nozzle 3D, 2.0 mm (10 pk)*	10
	PT347-0001X		46713300280-25	PT-Nozzle 3D, 2.5 mm (10 pk)*	10
	PT347-0002X		46713300280-30, 46713300430	PT-Nozzle 3D, 3.0 mm (10 pk)*	10
	PT347-0035X		46713300280-35	PT-Nozzle 3D, 3.5 mm (10 pk)*	10
	2	PT347-0004X		P0352-386-00010	PT-Nozzle 2D, 1.0 mm (10 pk)
PT347-0012X			46713300310	PT-Nozzle 2D, 1.2 mm (10 pk)	10
PT347-0310X			P0352-386-00015	PT-Nozzle 2D, 1.5 mm (10 pk)*	10
PT347-0300X			46713300300, P0352-387-00020	PT-Nozzle 2D, 2.0 mm (10 pk)*	10
PT347-0003X			46713300300-25	PT-Nozzle 2D, 2.5 mm (10 pk)*	10
PT347-0006X			46713300300-30	PT-Nozzle 2D, 3.0 mm (10 pk)*	10
3	PT347-0320		46713300321, P0352-311-00001	PT-Union Nut, Vespel	1

\*Parts available in single packs. To order single packs, remove the 'X' at the end of the part number (e.g. AM123-4567X would be AM123-4567).

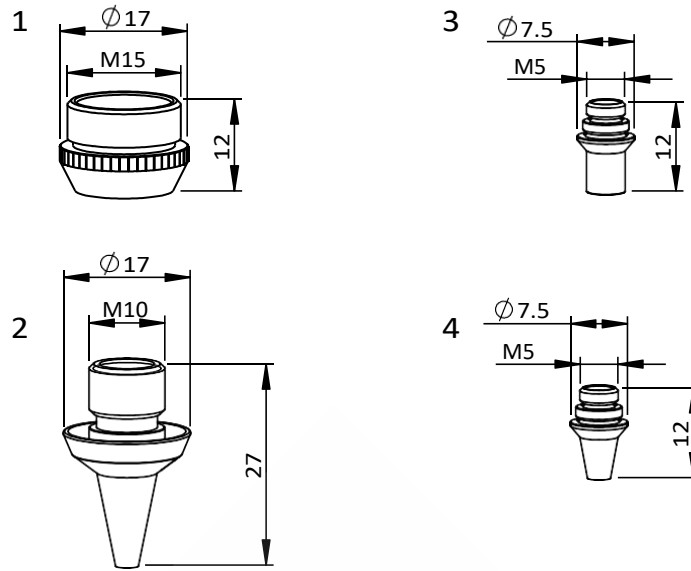
**Consumables**

	Centricut P/N	Raysoar P/N	OEM Ref. No.	Description	Pkg qty
1	MZ332-1280		46713331280	MZ-Nut, Vespel	1
2	MZ332-1305X			MZ-Nozzle 3D, 1.0 mm (10 pk)*	10
	MZ332-1320X		46713331320	MZ-Nozzle 3D, 1.2 mm (10 pk)*	10
	MZ332-1310X		46713331310	MZ-Nozzle 3D, 1.5 mm (10 pk)*	10
	MZ332-1301X			MZ-Nozzle 3D, 1.8 mm (10 pk)*	10
	MZ332-1300X		46713331300	MZ-Nozzle 3D, 2.0 mm (10 pk)*	10
	MZ332-1330X		46713331330	MZ-Nozzle 3D, 2.5 mm (10 pk)*	10
	MZ332-1290X		46713331290	MZ-Nozzle 3D, 3.0 mm (10 pk)*	10
3	PT347-1013X		281013, P0352-325-00015	PT-Nozzle ZK, 1.5 mm (10 pk)	10
	PT347-0899X		280899, P0352-326-00018	PT-Nozzle ZK, 1.8 mm (10 pk)	10
	PT347-0044X		350044.3, P0352-327-00020	PT-Nozzle ZK, 2.0 mm (10 pk)*	10
	PT347-1025X		350044.3, P0352-328-00025	PT-Nozzle ZK, 2.5 mm (10 pk)*	10
4	PT347-1006X		281006, P0352-333-00010	PT-Nozzle KK, 1.0 mm (10 pk)	10
	PT347-1031X		281031, P0352-335-00015	PT-Nozzle KK, 1.5 mm (10 pk)*	10
	PT347-0898X		280898, P0352-336-00018	PT-Nozzle KK, 1.8 mm (10 pk)	10
	PT347-1020X		P0352-336-00020	PT-Nozzle KK, 2.0 mm (10 pk)*	10

\*Parts available in single packs. To order single packs, remove the 'X' at the end of the part number (e.g. AM123-4567X would be AM123-4567).

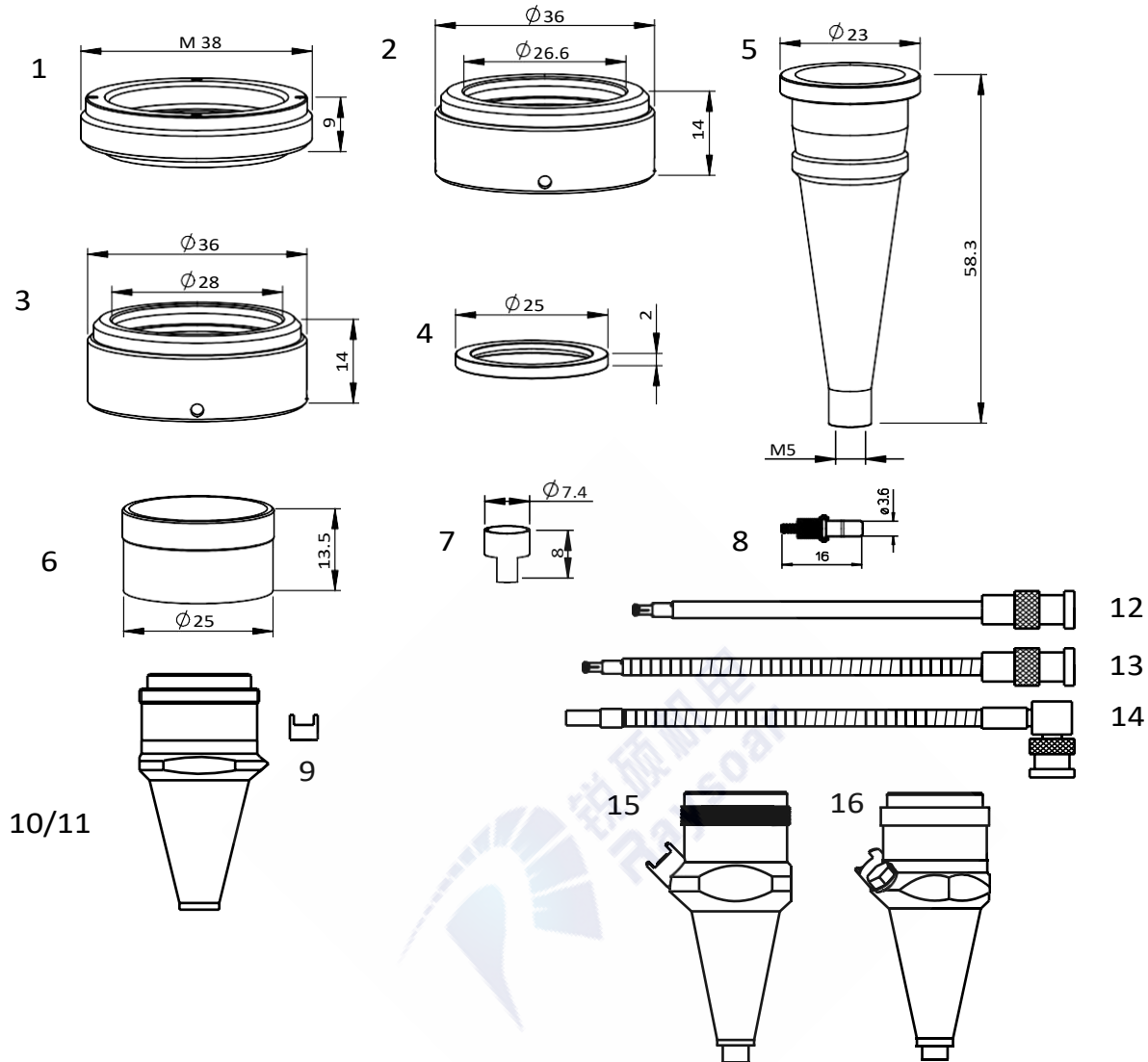
**Consumables**

	Centricut P/N	Raysoar P/N	OEM Ref. No.	Description	Pkg qty
1	PT347-4297		P0492-702-00001, 29100021	PT-Insulating ring outer body	1
	AM326-6453 (not shown)			AM-O-ring for outer nozzle	1
2	PT347-0008		46713330200	PT-Isolating ring outer body (Precitec)	1
3	PT347-0920		46713330920	PT-Isolating ring outer body (Mazak)	1
4	PT347-350		46713330960	PT-Isolating ring, inner cone	1
5	PT347-349		46713330930	PT-Sensor cone inner	1
6	PT347-0940		46713330940	PT-Retaining ring	1
7	PT347-0009		46713300390	PT-Connector protector	1
8	PT347-1111		46713331111	PT- Connector w/spring	1
9	PT347-9006			PT-Connector cup, HNP	1
10	PT347-1240		46713331240	PT-Torch outer body	1
11	PT347-0369			Complete outer torch (PT347-1240/1111/0009)	1
12	PT347-0101		P0360-100-00500, 46713300100	PT-Sensor head connecting cable OEM	1
13	PT347-1386		281386, P0360-155-00500	PT-Electrode cable	1
14	PT347-0181		46743300181	PT-Sensor cable	1
15	PT347-3323		567123323A1	PT-Sensor cone HNP	1
16	PT347-0007		P0354-110-00001	PT-Sensor cone HNZ	1

Raysoar is not affiliated with the named manufacturers. Reference to machines, parts, descriptions, and model numbers are for convenience in verifying compatibility only. All parts are made by or for Centricut and are not made by the referenced manufacturers (unless expressly indicated). All other trademarks are the properties of their respective owners. Raysoar is the authorized distributor of Centricut.



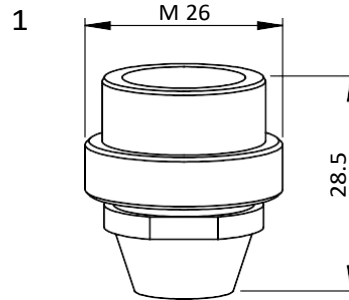

## Consumables

	Centricut P/N	Raysoar P/N	OEM Ref. No.	Description	Pkg qty
1	MZ321-0510		46603350510	MZ-Nozzle adapter body	1

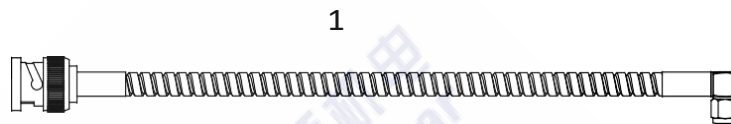

## Consumables

	Centricut P/N	Raysoar P/N	OEM Ref. No.	Description	Pkg qty
1	MZ335-1330A		46683301330	MZ-Sensor cable, 305 mm (12") armored	1
	MZ335-1980A		46683301980, 46683301982	MZ-Sensor cable, 280 mm (11") armored	1
	MZ335-0111A (not shown)		46743300111	MZ-Sensor cable, 280 mm (11") armored	1
	MZ335-0181A (not shown)		46743300181	MZ-Sensor cable, 317.5 mm (12.5") armored	1
	MZ335-5320 (not shown)		6143355320	MZ-Sensor cable, 70 mm (2.8") armored	1
	MZ335-630A (not shown)			MZ-Sensor cable, 630 mm (25") armored	1
	MZ335-HNPS (not shown)		HNPS	MZ-Sensor cone, HNP short version	1

## Consumables

	Centricut P/N	Raysoar P/N	OEM Ref. No.	Description	Pkg qty
	BY328-3884 (not shown)		333884	BY-Screws, plastic (2 pcs)	2
	AM313-2023 (not shown)		71232023	AM-Vacuum pump filter	1

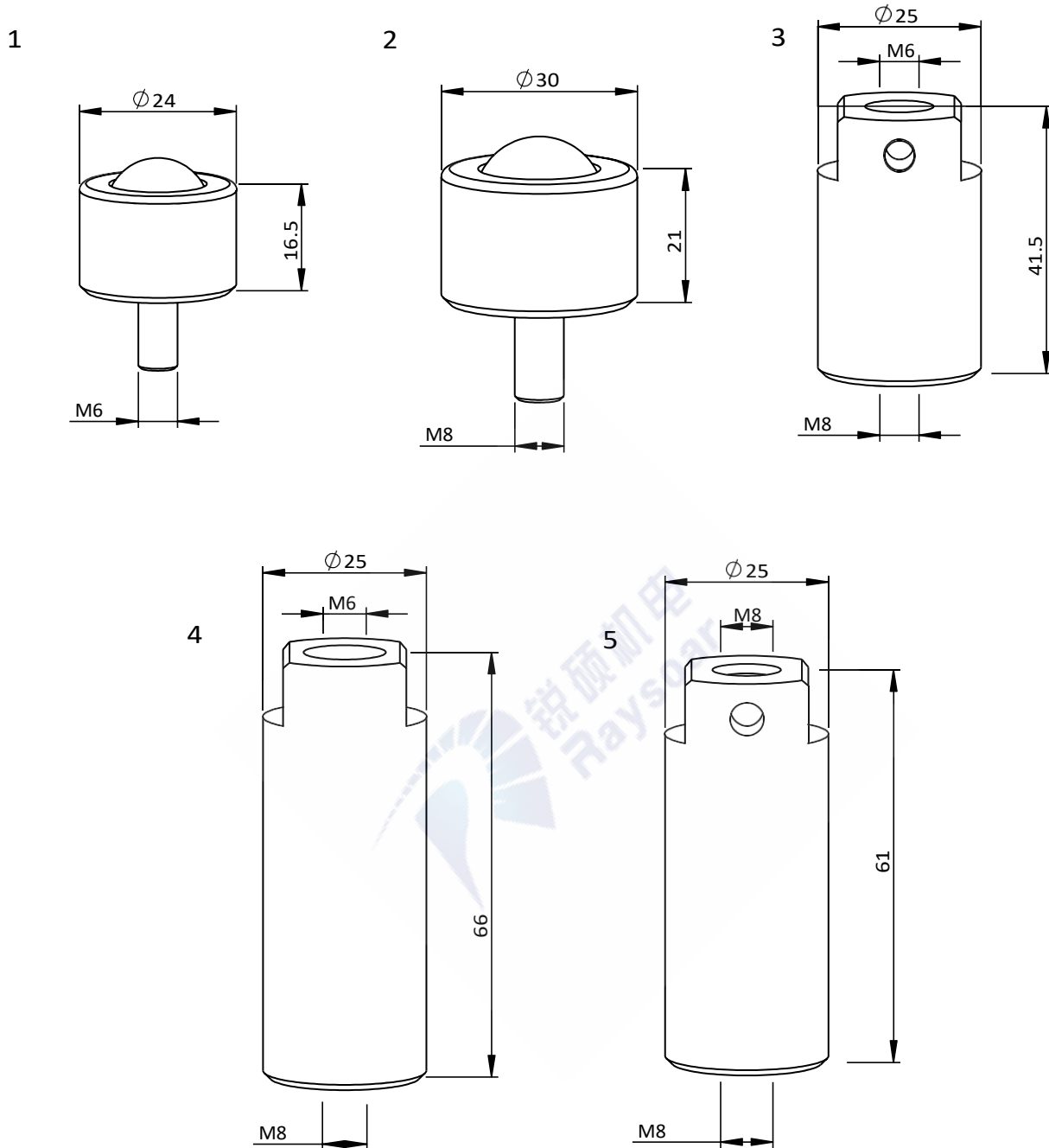
**Consumables**

	Centricut P/N	Raysoar P/N	OEM Ref. No.	Description	Pkg qty
1	MZ309-Z580		Z21KV000580	MZ-Roller ball M6, 25 mm	1
	MZ309-Z580X		Z21KV000580	MZ-Roller ball M6, 25 mm (10 pk)	10
	MZ309-Z580B		Z21KV000580	MZ-Roller ball M6, 25 mm	1
2	MZ309-1160		Z21ZZ001160	MZ-Roller ball M8, 30 mm	1
3	MZ309-0321		46575100321	MZ-Block, L41.5 stainless steel	1
4	MZ309-0050		46705100050	MZ-Block, L66 stainless steel	1
5	MZ309-0324			MZ-Block, stainless steel	1

Optics — CO2 Focus Lens



	Raysoar P/N	OEM Ref. No.	Description	Brandname
1	LAMO01-8662		Lens Plx 1.5"Dia/5.0"Fl/.300"ET	II-VI
2	LAMO01-6068		Lens Plx 1.5"Dia/7.5"FL/.300"ET	II-VI
3	LAMO01-1363	Z50ZZ013480	Lens Plx 2.0"Dia/5.0"FL/.380"ET	II-VI
4	LMZO01-2771	LX524035-2,Z50ZZ00520A,Z50ZZ005200, Z50ZZ013470	Lens Plx 2.0"Dia/7.5"FL/.380"ET	II-VI

	Raysoar P/N	OEM Ref. No.	Description	Brandname
1	LAMO01-1363A	Z50ZZ013480	Lens Plx 2.0"Dia/5.0"FL/.380"ET	Raypower
2	LMZO01-2771A	LX524035-2,Z50ZZ00520A,Z50ZZ005200, Z50ZZ013470	Lens Plx 2.0"Dia/7.5"FL/.380"ET	Raypower

CO2 Folding Mirror



	Raysoar P/N	OEM Ref. No.	Description	Brandname
1	LMZO02-1727		MIRROR BMSPLTR 1.5"/.120"50%I-POL	II-VI
2	LMZO02-1053		MIRROR BMSPLTR 1.5"/.120"50%P-POL	II-VI
3	LMZO02-7751		MIRROR BMSPLTR 1.5"/.120"50%S-POL	II-VI
4	LMZO02-8360	Z50ZZ008360	MIRROR CU ATFR 2.0"DIA/.375"ET 99.5%	II-VI
5	LMZO02-0070	Z50MB000070	MIRROR CU ZPS 2.0"DIA/.394"ET 99.5%	II-VI
6	LMZO02-0060	Z50ZZ008210,Z50MB0000602	MIRROR CU TRZ 2.36"DIA/.394"ET	II-VI
7	LMZO02-0860	Z50ZZ010860	MIRROR CU PS 2.0"DIA/.375"ET	II-VI
8	LMZO02-0040		MIRROR CU PS 1.5"DIA/.250"ET	II-VI
9	LMZO02-0686	Z50MB000040	MIRROR CU PS 1.5"DIA/.250"ET	II-VI
10	LMZO02-8280	Z50ZZ008280	MIRROR SI PS 2.0"DIA/.200"ET	II-VI
11	LMZO02-7694	BRDL00001-002, 25010	MIRROR CU RPR 2.0"DIA/.378"ET 90 DEG	II-VI
12	LMZO02-7260	Z50ZZ007260	MIRROR CU PS 3.0"DIA/.250"ET	II-VI
13	LMZO02-0030	Z50MB000030	MIRROR CU TRZ 1.575"DIA/.295"ET/45DEG	II-VI
14	LMZO02-0060	Z50MB000060	MIRROR CU TRZ 2.362"DIA/.374"ET	II-VI
15	LMZO02-4184	4L104184-01	MIRROR SI TRZ 1.75"DIA/.375"ET	II-VI
16	LMZO02-8690	Z50MB008690	MIRROR SI TRZ 1.75"DIA/.375"ET	II-VI

## CO2 Optics for Oscillator CO2



	Raysoar P/N	OEM Ref. No.	Description	Type of Oscillator	Brandname
1	LMZO01-W813	W813	MIRROR ZNSE COL 1.5"DIA/.15.0M/.157"ET		II-VI
2	LMZO01-MA15	FSCOLLIMA15	MIRROR ZNSE COL 1.5"DIA/590.55"FL/.119"ET		II-VI
3	LMZO03-4808	Z50MB004740 BRAL0020 4L104808	MIRROR ZNSE OC 1.1"DIA/.220"ET/10MCC5MCX-90		II-VI
4	LMZO03-8510	Z50MB008510,BRAL0019	MIRROR ZNSE OC 1.1"DIA/.220"ET/15MCC-65%		II-VI
5	LMZO03-0014	BRAL0014	MIRROR ZNSE OC 1.1"DIA/.220"ET/20MCC15MCX-40		II-VI
6	LMZO03-5420	Z50MB005420, 4L106107,BRCL0010	MIRROR ZNSE OC 1.1"DIA/.220"ET/20MCC15MCX-50		II-VI
7	LMB003-0590	Z50MB010590	MIRROR ZNSE OC 1.1"DIA/.220"ET/20MCC15MCX-60		II-VI
8	LMZO03-0007	BRAL0007	MIRROR ZNSE OC 1.1"DIA/.220"ET/20MCC20MCX-70		II-VI
9	LMZO03-0560	Z50MBB010560, BRAL0036	MIRROR ZNSE OC 1.1"DIA/.220"ET/20MCC15MCX-75		II-VI
10	LMZO03-0008	BRAL0008,4L106107	MIRROR ZNSE OC 1.1"DIA/.220"ET/20MCC-50		II-VI
11	LMZO03-8670	Z50MB008670	MIRROR ZNSE OC 1.1"DIA/.220"ET/10MCC7.5MCX-60		II-VI
12	LMZO03-6662		MIRROR ZNSE OC 1.1"DIA/.220"ET/20MCC50MCX-50		II-VI
13	LMZO04-1407	4L104183	MIRROR GE RM 1.1"DIA/.220"ET/20MCC 99.5%		II-VI
14	LMZO04-8500	Z50MB008500,BRBL0005	MIRROR GE RM 1.1"DIA/.220"ET/15MCC-99.5%		II-VI
15	LMZO04-0002	Z50MB010580,BRAL0002	MIRROR GE RM 1.1"DIA/.220"ET/20MCC0.6MCX-99.5		II-VI
16	LMZO04-8100	Z50MB008680 BRBL0006	MIRROR GE RM 1.1"DIA/.220"ET10MCC0.6MCX-99.5		II-VI

## Fiber Optics



	Raysoar P/N	OEM Ref. No.	Part Name	Description	Brandname
1	LMZO11-4290S	Z50SA015350	Protective Window	Fused Silica PW D42.00 T9.0 AR/AR@1064nm	Raypower

**Air Filter**

	Raysoar P/N	OEM Ref.No.	Description
1	LMZP07-2630	G48SV002630	FILTER SMC AMH-EL150
2	LMZP07-2640	G48SV002640	FILTER SMC AME-EL150
3	LMZP07-2650	G48SV002650	FILTER SMC AMF-EL150
4	LMZP07-3330	G48SV003330 / G48SV00323A	FILTER SMC AMH-EL350
5	LMZP07-1420	G48SV001420	FILTER SMC AME-EL350 SUPER MIST SEPARAT,AME350-03
6	LMZP07-3350	G48SV003350,G48SV00325A	FILTER SMC AMF-EL350 ODOUR REMOVAL,AMF350-03B
7	LMZP07-2690	G48SV002690	FILTER SMC AMH-EL250
8	LSMP07-151A	G48SV00151A	AIR FILTER SMC (AMD-EL250-X231)
9	LMZP07-1430	U01QQ001430	F300-03BG-A
10	LMZP07-03B	AFF4B-03B	FILTER SMC AFF4B-03B
11	LMZP07-F03	EAD202-F03	FILTER SMC SUN DRAIN CATCH AS202-03
12	LMZP07-0160	H50ZZ000160	BK 9900-05 TUBE FILTER

**Oscillater**

	Raysoar P/N	OEM Ref. No.	Description
1	LLBM07-2023	Z50MBP0090, 71199197	Vacuum pump filter
3	LLBM06-GS32-2	LVO120	Vacum pump oil LVO 120 2L
4	LFAM06-T560		AeroShell Turbine Oil 560

## Lubrication Grease



	Raysoar P/N	OEM Ref. No.	Description
1	LMZM06-SIMA		SIMALUBE GREASE FOR FIBRE LASER
2	LMZM06-MPO4		MPO-4 400ml





1



2



3



4



5



6



7



8



9



10



11



12



13



14

	Raysoar P/N	OEM Ref. No.	Description
1	LOPC15-1260		LENS STRESS VISUALIZER Ø 1.5" (Ophir EZ Test) (1.5")
	LOPC15-1280		LENS STRESS VISUALIZER Ø 2.0" (Ophir EZ Test) (2.0")
2	LTRC15-7388		Mirror Polish .1UM 80ML
3	LRSC15-ALCO-500		Ethanol 99.7%
4	LRSC15-A236		IPA Isopropyl A236 400ml
5	LRSC15-GSBL		Air Duster 85g
6	LRSC15-FCS3		Optics Cleaning Liquid (Imported) 58ml
7	LRSC15-ACET-500		Optics Cleaning Liquid 500ml
8	LRSC15-0714		Knit polyester swabs 20pcs
9	LRSC15-759B		Knit polyester swabs 100pcs
10	LRSC15-9625		Knit polyester swabs 50pcs
11	TR300-6452		Original Tiffen Lens Cleaning Paper (50 sheets)
12	LRSC15-CLPA		Domestic Lens Cleaning Paper (40 sheets)
13	TR300-1115		Lens cleaning cotton pads -80 pcs
14	LRSC15-KT3008		Cleanroom wipers KX KT-3008 9"